

EcoStruxure Machine Expert - Basic Example Guide

TM3 Safety Module Usage
xSample_TM3_Safety.smbe

12/2018

The information provided in this documentation contains general descriptions and/or technical characteristics of the performance of the products contained herein. This documentation is not intended as a substitute for and is not to be used for determining suitability or reliability of these products for specific user applications. It is the duty of any such user or integrator to perform the appropriate and complete risk analysis, evaluation and testing of the products with respect to the relevant specific application or use thereof. Neither Schneider Electric nor any of its affiliates or subsidiaries shall be responsible or liable for misuse of the information contained herein. If you have any suggestions for improvements or amendments or have found errors in this publication, please notify us.

You agree not to reproduce, other than for your own personal, noncommercial use, all or part of this document on any medium whatsoever without permission of Schneider Electric, given in writing. You also agree not to establish any hypertext links to this document or its content. Schneider Electric does not grant any right or license for the personal and noncommercial use of the document or its content, except for a non-exclusive license to consult it on an "as is" basis, at your own risk. All other rights are reserved.

All pertinent state, regional, and local safety regulations must be observed when installing and using this product. For reasons of safety and to help ensure compliance with documented system data, only the manufacturer should perform repairs to components.

When devices are used for applications with technical safety requirements, the relevant instructions must be followed.

Failure to use Schneider Electric software or approved software with our hardware products may result in injury, harm, or improper operating results.

Failure to observe this information can result in injury or equipment damage.

© 2018 Schneider Electric. All rights reserved.

Table of Contents



	Safety Information	5
	About the Book	9
Chapter 1	Example Description	13
	Description.....	14
	Output Activation Management.....	15
	Template Description.....	17

Safety Information



Important Information

NOTICE

Read these instructions carefully, and look at the equipment to become familiar with the device before trying to install, operate, service, or maintain it. The following special messages may appear throughout this documentation or on the equipment to warn of potential hazards or to call attention to information that clarifies or simplifies a procedure.



The addition of this symbol to a “Danger” or “Warning” safety label indicates that an electrical hazard exists which will result in personal injury if the instructions are not followed.



This is the safety alert symbol. It is used to alert you to potential personal injury hazards. Obey all safety messages that follow this symbol to avoid possible injury or death.

DANGER

DANGER indicates a hazardous situation which, if not avoided, **will result in** death or serious injury.

WARNING

WARNING indicates a hazardous situation which, if not avoided, **could result in** death or serious injury.

CAUTION

CAUTION indicates a hazardous situation which, if not avoided, **could result in** minor or moderate injury.

NOTICE

NOTICE is used to address practices not related to physical injury.

PLEASE NOTE

Electrical equipment should be installed, operated, serviced, and maintained only by qualified personnel. No responsibility is assumed by Schneider Electric for any consequences arising out of the use of this material.

A qualified person is one who has skills and knowledge related to the construction and operation of electrical equipment and its installation, and has received safety training to recognize and avoid the hazards involved.

BEFORE YOU BEGIN

Do not use this product on machinery lacking effective point-of-operation guarding. Lack of effective point-of-operation guarding on a machine can result in serious injury to the operator of that machine.

 WARNING
UNGUARDED EQUIPMENT
<ul style="list-style-type: none">• Do not use this software and related automation equipment on equipment which does not have point-of-operation protection.• Do not reach into machinery during operation.
Failure to follow these instructions can result in death, serious injury, or equipment damage.

This automation equipment and related software is used to control a variety of industrial processes. The type or model of automation equipment suitable for each application will vary depending on factors such as the control function required, degree of protection required, production methods, unusual conditions, government regulations, etc. In some applications, more than one processor may be required, as when backup redundancy is needed.

Only you, the user, machine builder or system integrator can be aware of all the conditions and factors present during setup, operation, and maintenance of the machine and, therefore, can determine the automation equipment and the related safeties and interlocks which can be properly used. When selecting automation and control equipment and related software for a particular application, you should refer to the applicable local and national standards and regulations. The National Safety Council's Accident Prevention Manual (nationally recognized in the United States of America) also provides much useful information.

In some applications, such as packaging machinery, additional operator protection such as point-of-operation guarding must be provided. This is necessary if the operator's hands and other parts of the body are free to enter the pinch points or other hazardous areas and serious injury can occur. Software products alone cannot protect an operator from injury. For this reason the software cannot be substituted for or take the place of point-of-operation protection.

Ensure that appropriate safeties and mechanical/electrical interlocks related to point-of-operation protection have been installed and are operational before placing the equipment into service. All interlocks and safeties related to point-of-operation protection must be coordinated with the related automation equipment and software programming.

NOTE: Coordination of safeties and mechanical/electrical interlocks for point-of-operation protection is outside the scope of the Function Block Library, System User Guide, or other implementation referenced in this documentation.

START-UP AND TEST

Before using electrical control and automation equipment for regular operation after installation, the system should be given a start-up test by qualified personnel to verify correct operation of the equipment. It is important that arrangements for such a check be made and that enough time is allowed to perform complete and satisfactory testing.

WARNING

EQUIPMENT OPERATION HAZARD

- Verify that all installation and set up procedures have been completed.
- Before operational tests are performed, remove all blocks or other temporary holding means used for shipment from all component devices.
- Remove tools, meters, and debris from equipment.

Failure to follow these instructions can result in death, serious injury, or equipment damage.

Follow all start-up tests recommended in the equipment documentation. Store all equipment documentation for future references.

Software testing must be done in both simulated and real environments.

Verify that the completed system is free from all short circuits and temporary grounds that are not installed according to local regulations (according to the National Electrical Code in the U.S.A, for instance). If high-potential voltage testing is necessary, follow recommendations in equipment documentation to prevent accidental equipment damage.

Before energizing equipment:

- Remove tools, meters, and debris from equipment.
- Close the equipment enclosure door.
- Remove all temporary grounds from incoming power lines.
- Perform all start-up tests recommended by the manufacturer.

OPERATION AND ADJUSTMENTS

The following precautions are from the NEMA Standards Publication ICS 7.1-1995 (English version prevails):

- Regardless of the care exercised in the design and manufacture of equipment or in the selection and ratings of components, there are hazards that can be encountered if such equipment is improperly operated.
- It is sometimes possible to misadjust the equipment and thus produce unsatisfactory or unsafe operation. Always use the manufacturer's instructions as a guide for functional adjustments. Personnel who have access to these adjustments should be familiar with the equipment manufacturer's instructions and the machinery used with the electrical equipment.
- Only those operational adjustments actually required by the operator should be accessible to the operator. Access to other controls should be restricted to prevent unauthorized changes in operating characteristics.

About the Book



At a Glance

Document Scope

This document describes a EcoStruxure Machine Expert - Basic example application that allows you to operate and control a TM3 Safety module.

The examples described here are intended for learning purposes only. In general, they are intended to help you understand how to develop, test, commission, and integrate application logic and/or the device wiring of the equipment associated with your own design in your control systems. The examples are not intended to be used directly on products that are part of a machine or process.

WARNING

UNINTENDED EQUIPMENT OPERATION

Do not include any wiring information, programming or configuration logic, or parameter values from any of the examples in your machine or process without thoroughly testing your entire application.

Failure to follow these instructions can result in death, serious injury, or equipment damage.

This document and its related EcoStruxure Machine Expert - Basic project file focus on specific instructions and function blocks provided with EcoStruxure Machine Expert - Basic, and on specific features available in EcoStruxure Machine Expert - Basic. They are intended to help you understand how to develop, test, commission, and integrate applicative software of your own design in your control systems.

The example is intended for new EcoStruxure Machine Expert - Basic users who already have some degree of expertise in the design and programming of control systems.

Validity Note

This document has been updated for the release of EcoStruxure™ Machine Expert - Basic V1.0.

Product Related Information

WARNING

LOSS OF CONTROL

- The designer of any control scheme must consider the potential failure modes of control paths and, for certain critical control functions, provide a means to achieve a safe state during and after a path failure. Examples of critical control functions are emergency stop and overtravel stop, power outage and restart.
- Separate or redundant control paths must be provided for critical control functions.
- System control paths may include communication links. Consideration must be given to the implications of unanticipated transmission delays or failures of the link.
- Observe all accident prevention regulations and local safety guidelines.¹
- Each implementation of this equipment must be individually and thoroughly tested for proper operation before being placed into service.

Failure to follow these instructions can result in death, serious injury, or equipment damage.

¹ For additional information, refer to NEMA ICS 1.1 (latest edition), "Safety Guidelines for the Application, Installation, and Maintenance of Solid State Control" and to NEMA ICS 7.1 (latest edition), "Safety Standards for Construction and Guide for Selection, Installation and Operation of Adjustable-Speed Drive Systems" or their equivalent governing your particular location.

WARNING

UNINTENDED EQUIPMENT OPERATION

- Only use software approved by Schneider Electric for use with this equipment.
- Update your application program every time you change the physical hardware configuration.

Failure to follow these instructions can result in death, serious injury, or equipment damage.

WARNING

UNINTENDED EQUIPMENT OPERATION

Do not include any wiring information, programming or configuration logic, or parameter values from any of the examples in your machine or process without thoroughly testing your entire application.

Failure to follow these instructions can result in death, serious injury, or equipment damage.

Related Documents

Title of Documentation	Reference Number
EcoStruxure Machine Expert - Basic - Operating Guide	<u>EIO0000003281 (ENG)</u> <u>EIO0000003282 (FRE)</u> <u>EIO0000003283 (GER)</u> <u>EIO0000003284 (SPA)</u> <u>EIO0000003285 (ITA)</u> <u>EIO0000003286 (CHS)</u> <u>EIO0000003287 (POR)</u> <u>EIO0000003288 (TUR)</u>

Chapter 1

Example Description

What Is in This Chapter?

This chapter contains the following topics:

Topic	Page
Description	14
Output Activation Management	15
Template Description	17

Description

Main Features

The TM3 safety modules are digital I/O functional safety modules. They can be used to incorporate machine safety into the overall machine control.

They are designed to connect to M2•• logic controllers.

The safety-related functions are managed uniquely by the safety module, independent from the rest of the system. Any communication-dependent function is not considered as safety-related.

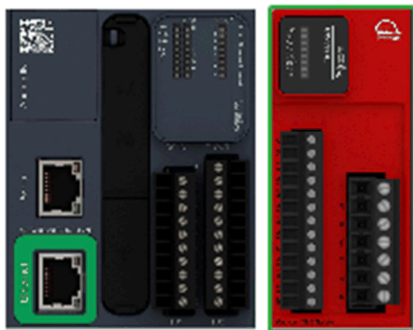

Output Activation Management

TM3SAK6R Description

The TM3SAK6R is a safety module for monitoring emergency stop and limit switches on protective guards, safety light curtains, and safety-mats.

Output Activation

The following illustration represents the output activation management in a 2-channel application with a non-monitored start:

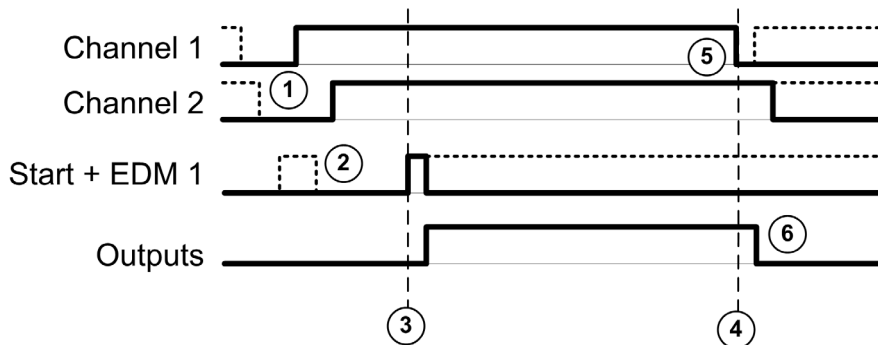

I/O behavior	Status
	TRUE
	FALSE
	Optional

- (1) Both **S2** and **S3** (**Channel 1** and **Channel 2**, respectively) inputs must be set to FALSE before the outputs can be activated. This condition is called Interlock. For more information, refer to the TM3 Expansion Modules Configuration Programming Guide for your software platform.
- (2) Non-monitored start condition is available as long as the input is TRUE.
The start condition can be valid before the safety inputs are valid.
The outputs are TRUE only if start + safety inputs conditions are valid.
- (3) Safety inputs + start conditions are valid.
- (4) Safety inputs condition invalid.
- (5) At least 1 input is FALSE
- (6) The outputs react to the safety inputs and start conditions with a delay given by system constraints.

Wiring Diagram

The example project depends on the non-monitored start input for an emergency stop, wired on the inputs at **S21-S22** and **S31-S32**:

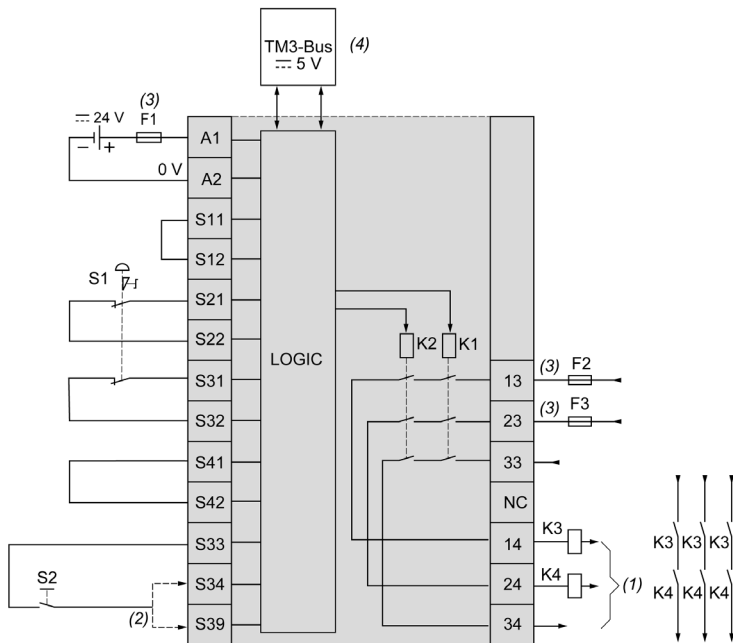

S1: Emergency stop switch

S2: Start switch

(1): Safety outputs

(2): Non-monitored start

(3): Fuses. Refer to electrical characteristics for fuse values

(4): Non-safety related TM3 Bus communication with logic controller

Template Description

Template File

The following illustration shows the template file delivered with EcoStruxure Machine Expert - Basic:

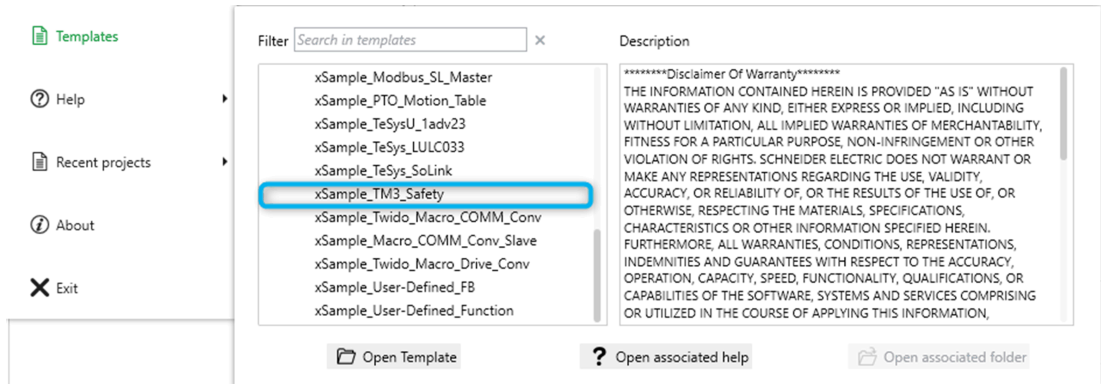

Example Template Program Structure

The following illustration shows the task structure in the **Tasks** tab:

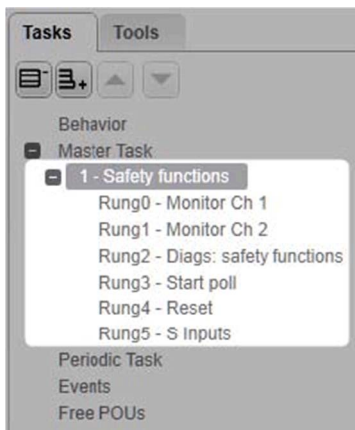

The following illustration shows one of the tasks open in the **Programming** tab of EcoStruxure Machine Expert - Basic:

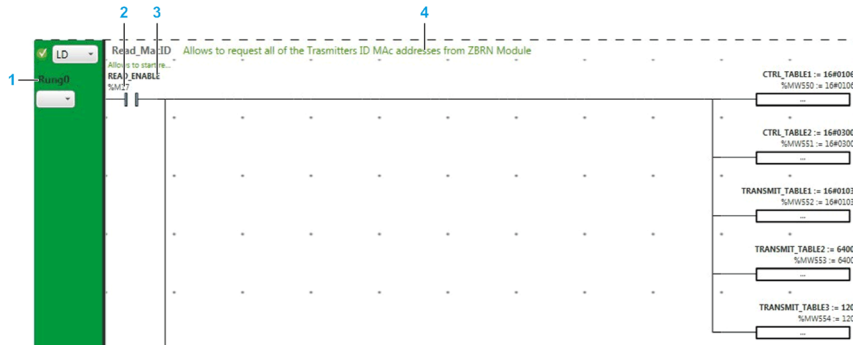

- 1 The rung name
- 2 The memory but used in the operation
- 3 The symbol associated with the memory bit
- 4 An optional rung comment

Animation Table Structure

The following illustration shows the animation table provided with the template:

Used	Address	Symbol	Value	Force	Comment
<input checked="" type="checkbox"/>	%M0		1		
<input checked="" type="checkbox"/>	%M4	START_ENABLED	0		
<input checked="" type="checkbox"/>	%M5	STARTENABLE_RESET	0		
<input checked="" type="checkbox"/>	%Q1.0	ENABLE	1	Not Forced	Activation of Safety outputs enabled
<input type="checkbox"/>	%Q1.1	RESET_MODULE	0	Not Forced	Deactivate module (current source switched off)
<input type="checkbox"/>	%Q1.2	KEEP_ALIVE	0	Not Forced	Safety function stays active even when bus is 'dead' (timeout)
<input type="checkbox"/>	%Q1.3	SYNC_ON	0	Not Forced	Synchronization time monitoring active
<input checked="" type="checkbox"/>	%I1.0	SAFETY_OUTPUT_ON	0	Not Forced	
<input checked="" type="checkbox"/>	%I1.1	SUPPLY_OK	1	Not Forced	
<input checked="" type="checkbox"/>	%I1.2	SUPPLYOUT_TOLERANCE	0	Not Forced	
<input checked="" type="checkbox"/>	%I1.3	CHANNEL1_ACTIVE	1	Not Forced	
<input checked="" type="checkbox"/>	%I1.4	CHANNEL2_ACTIVE	1	Not Forced	
<input checked="" type="checkbox"/>	%I1.5	START_ACTIVE	0	Not Forced	
<input checked="" type="checkbox"/>	%I1.6	RELAY_K1_ACTIVATED	0	Not Forced	
<input checked="" type="checkbox"/>	%I1.7	RELAY_K2_ACTIVATED	0	Not Forced	
<input checked="" type="checkbox"/>	%I1.8	S1_ACTIVE	1	Not Forced	
<input checked="" type="checkbox"/>	%I1.9	S2_ACTIVE	1	Not Forced	
<input checked="" type="checkbox"/>	%I1.10	S3_ACTIVE	1	Not Forced	
<input checked="" type="checkbox"/>	%I1.11	S4_ACTIVE	1	Not Forced	
<input checked="" type="checkbox"/>	%I1.12	WAITING_FOR_START	1	Not Forced	Waiting for start condition
<input checked="" type="checkbox"/>	%I1.13	SYNCHRO_FAILURE	0	Not Forced	Synchronicity failure, Reoperate S2 and S3.

The safety monitoring is active if:

- Enable is set to TRUE (see %Q1.0).
- Reset is set to FALSE.
- Emergency inputs are in the defined safe-state condition. In this example, the emergency stop must be closed.

When the safety monitoring is active, the **K1** and **K2** LEDs blink and %I1.12 is TRUE. You can switch **S2**.

When you switch **S2**:

1. Start_Enabled (%M4) is set to TRUE.
2. Waiting_for_start is set to FALSE (%I1.12).
3. **K1** and **K2** LEDs are steady.
4. Relay_K1_activated and Relay_K2_activated are set to TRUE.

